

3RW-W0795-00

キックセット

適応機種  
SEROW225  
(3RW/4JG/5MP)

はじめに

お客様へ

ヤマハアクセサリをお買い上げ誠にありがとうございます。  
本書には商品の正しい組付方法と注意事項について説明してあります。性能を十分発揮し、安全にお使いいただくために、本書をよく読みいただきますようお願い申し上げます。

販売店様へ

本製品の商品説明および取り扱い上の注意点を、お客様に充分ご説明いただき、本書および本品の取付に際して取り外した部品は、必ずお客様にお渡しください。

This part is for the customer: It essentially just mentions that you should take care when installing.

構成部品

Torque setting 12-16 ft-lbs

No.	Part list - Bag B	部品番号	備考
①	1. Kick Axle	H-15660-01	B袋
②	2. Horseshoe Clip	468-26122	
③	3. Cover, Spring	1-15676-00	
④	4. Spacer	A-15666-00	
⑤	5. Spring, tension	508-26538	
⑥	6. Circlip	009-17400	
⑦	7. Washer, tabbed	209-17226	
⑧	8. Gear, starter	X-15641-00	
⑨	9. Washer	201-175F6	
⑩	10. Oil seal	102-17263	
⑪	Part list - Bag A	201-173F4	A袋
⑫	11. Washer	A-15651-01	
⑬	12. Gear, Kick idle	214-17028	
⑭	Part list - Bag C	009-17400	C袋
⑮	13. Washer, flat side	H-15620-00	
⑯	14. Circlip	017-08030	
⑰	Part list - Bag C	215-14186	
⑱	15. Kick Lever	210-48364	
⑲	16. Bolt	E-15462-00	
	17. Washer, Lock		
	18. O Ring		
	19. Gasket		

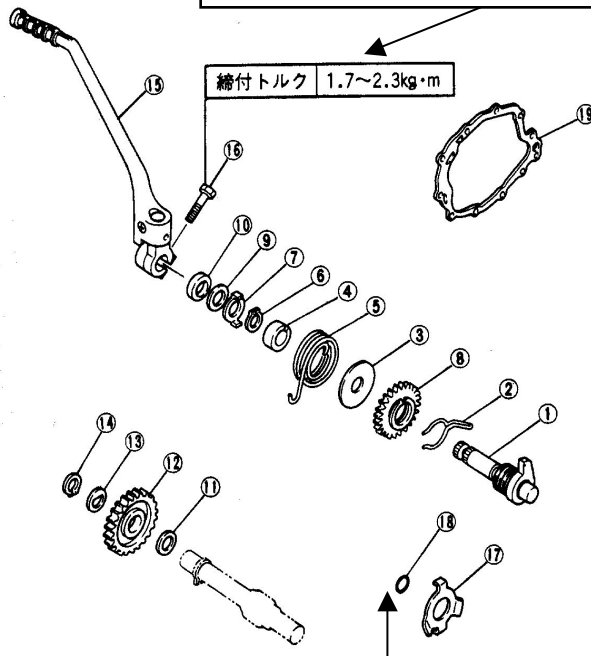

90201-175F6

※⑱-Oリングは5MP以降使用し

You do not use the O ring (18) after model 5MP.

The 2004 model does not have this O-ring.

準備する物

- |                            |                            |
|----------------------------|----------------------------|
| ① 8mmのソケットレンチおよびラチェットハンドル  | ⑧ トルクレンチ                   |
| ② 10mmのソケットレンチおよびラチェットハンドル | ⑨ プラスチックハンマー               |
| ③ 24mmのソケットレンチおよびラチェットハンドル | ⑩ サークリッププライヤー              |
| ④ クラッチホルダ (90890-04086)    | ⑪ エンジンオイル                  |
| ⑤ マイナスドライバー2本              | ⑫ モリブデングリス                 |
| ⑥ プラスドライバー、プラスショックドライバー    | ⑬ サービスマニュアル (1KH-28197-00) |
| ⑦ プライヤー                    |                            |

Tools and materials needed to do the installation - 8mm, 10mm, 24mm sockets spanners, Clutch holder, 2 Screw drivers, 1 Philips head screw driver, Pliers, Torque wrench, Plastic hammer, Circlip pliers, engine oil, grease, Service manual.

2-8058 静岡県浜松市新橋町1103

株式会社 **ワイズギア**

TEL 053-443-2180 FAX 053-443-2187

Assembly instructions:

1. Put together the subassembly as shown in figure 1. The horseshoe clip (2) goes on the starter gear (8) so that the extension points away from the gear. The tip of tension spring (5) fits into hole on kick axle (1). The spacer (4) has one side with a single dimple which covers the tip of tension spring (5) as it enters the kick axle (1).
2. Remove the engine protector.
3. Drain the engine oil.
4. Remove the rear brake pedal.
5. Remove the right hand side foot rest
6. Remove the crank case cover. See pg 4-15 in service manual. If there is corrosion on the dowel pins, the cover may be difficult to remove. Just gently tap it and rock it and avoid the temptation to pry it off which could damage the gasketed surfaces.
7. Remove the clutch. Use the special clutch holding tool to avoid damage to clutch boss. See pg 4-16 in service manual.
8. Refer to figure 2. Remove the circlip and spacer (the ones referenced by the dashed lines and Japanese characters) from the idle shaft. These two parts can be set aside, for they are not required for the kickstarter. Place washer (11), kick idle gear (12), flat sided washer (13), and new circlip (14) onto the idle shaft.
9. Refer to figure 3. Add the tabbed-washer (7) and washer (9) to the sub-assembly put together in step 1. Align the two tabs on tabbed washer plate (7) with the two indents in the spacer (4).
10. Refer to figure 2. Place the sub assembly from step 9 into the crankcase. Squirt some engine oil into the hole where kick axle seats. Align the extension of the horseshoe clip (2) with the indent in the crank case (directly at the bottom). Wind the torsion spring half a turn and hook on to projection B.
11. Now is a good time to clean off the old gasket material. It is easier to clean the crankcase side without the clutch basket in the way.
12. Install the clutch. See pgs 4-71 to 4-73 in the service manual. Use the new lock washer (17) when installing the clutch boss bolt. If you have an O-ring on your clutch push-rod shaft, use the new one (18) supplied with the kit.
13. Refer to figure 4. Remove the crank case cover (Λ) plug and replace it with the included oil seal (10). Apply some grease to the inner part of oil seal to help it slide over the kick axle.
14. Install the crank case cover. See pg 4-74 in the service manual. Be careful not to damage the oil seal. Use the new gasket (19) included in kit. The grey cross hatch side of the gasket (19) goes up against the crank case cover.
15. Install the right foot rest. Torque bolt to 30 ft-lbs.
16. Install the brake pedal. Torque pivot bolt to 22 ft-lbs.
17. Attach the kick lever (15) and tighten the bolt to 12-16 ft-lbs. Ensure the kick lever (15) does not hit the frame or crank case cover throughout its full range of motion or while stowed.
18. Add engine oil.
19. Install the engine protector.

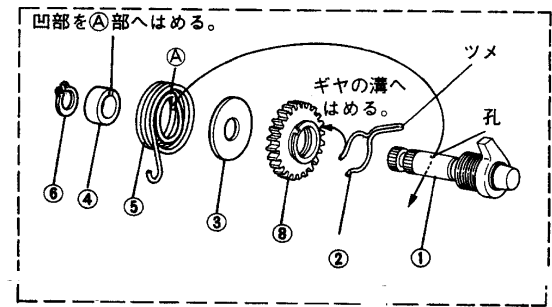

Figure 1

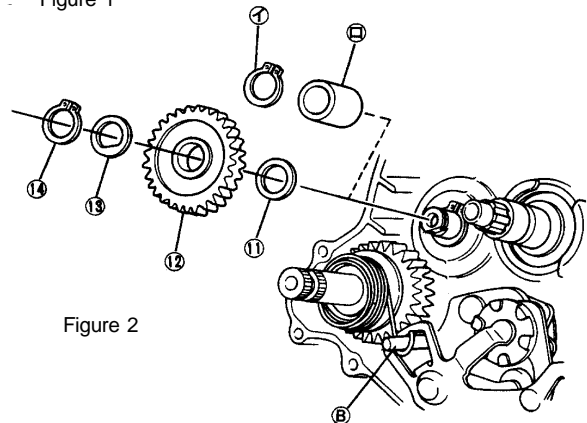

Figure 2

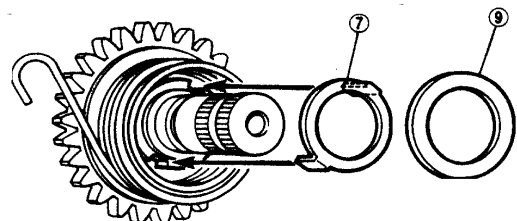

Figure 3

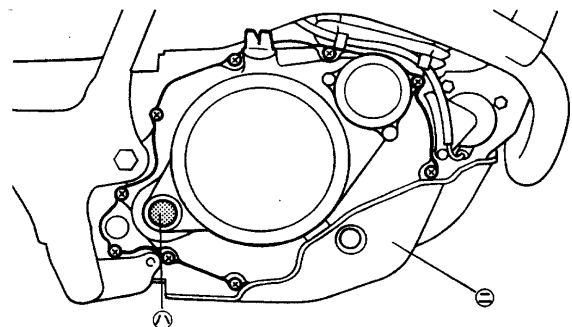

Figure 4